

WIGGINS YARD eBULL

W100/120/155Ye

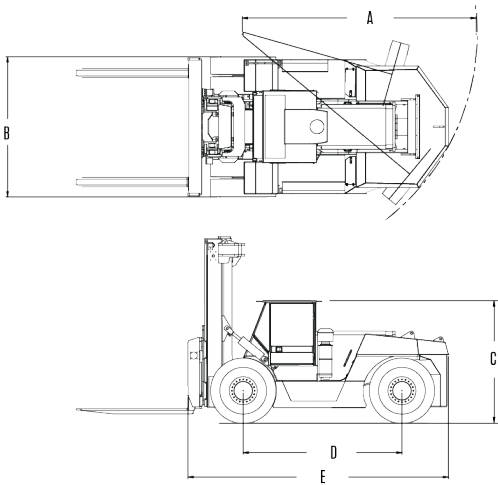

Chassis Data



W100/120/155Ye

A	B	C	D	E
151"	82"	98"	108"	161"

Specifications

Model/Capacity:	W100/120/155Ye
OAL (E)	161"
Wheelbase (D)	108"
Width (B)	82"
Min. Out Turn Radius (A)	151"
Fork Dimensions	2.5" x 6" x 96"
Weight	18000 / 20000 / 23000
Tires - Size/Drive	8.25x15
Tires - Size/Drive	8.25x15

Battery Capacity	Lithium Ion - 50kWh Usable
Drive Axle	Kessler D41

Mast Data

Model/Capacity:	W100/120/155Ye
Lift Height	156"
Overall Lowered Height	124"
*Other Mast Lift Heights Available	

Full Rated Capacities

W100Ye	10,000 lbs @ 24" LC
W120Ye	12,000 lbs @ 24" LC
W155Ye	15,500 lbs @ 24" LC

DEALER INFORMATION:

XLLifts

info@xlliftsinc.com
 www.XLLiftsinc.com
 Sales: 805.889.8487
 General inquiries: 805.765.6099